

kitko.

KITCHEN SOLUTIONS

# 600mm 3 DRAWER CABINET

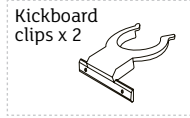
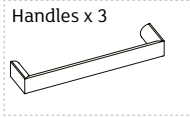
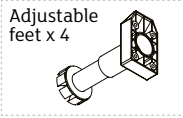
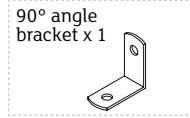
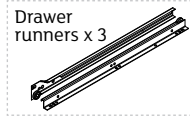

## STEP 1

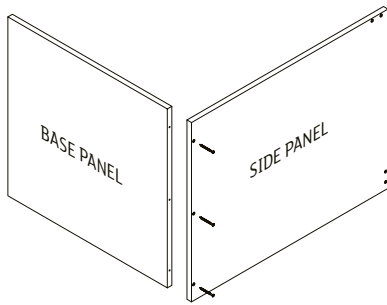

Screw base panel into side panel.

## STEP 2

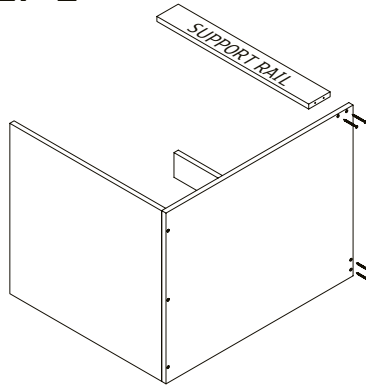

Screw support rails in position.

## STEP 3

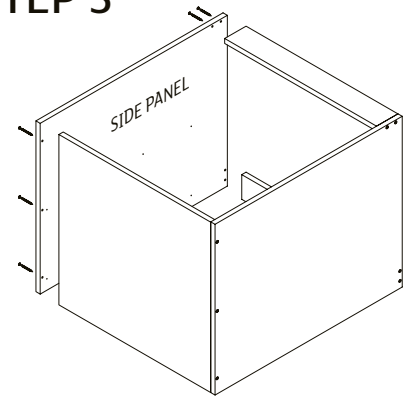

Attach remaining side panel.

## STEP 4

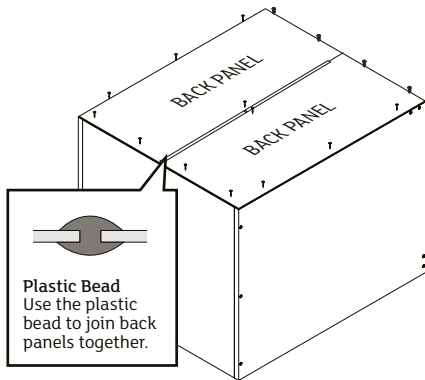

Nail back panel onto the side panels, base panels and fixed shelf. Screw the back panel into the top support rail.

## STEP 5

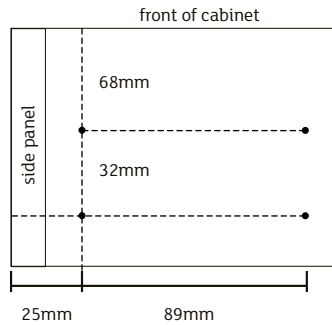

Turn the cabinet over. Mark out the dimensions shown.

## STEP 6

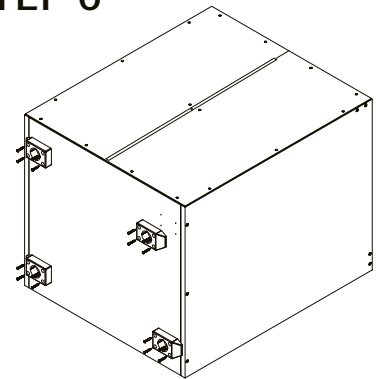

Screw the base plates for the adjustable leg in position.

## STEP 7

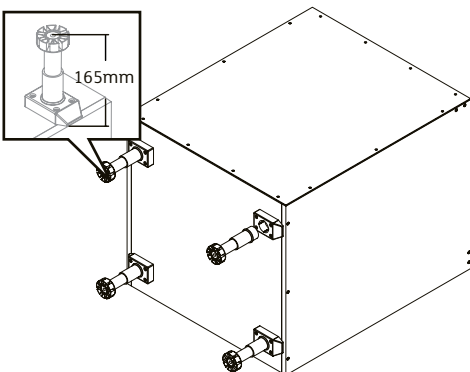

Attach leg to the base plate. Set the height of the adjustable legs to 165mm. Repeat for the remaining legs.

## STEP 8

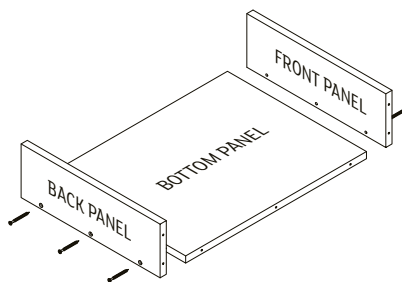

Attach the front and back drawer box panels to the base drawer box panel.

## STEP 9

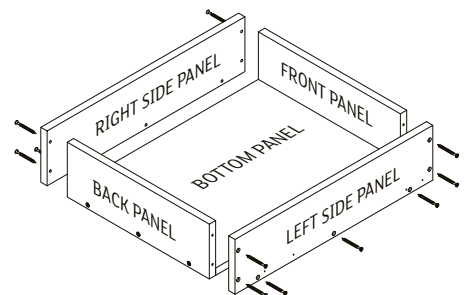

Attach the side panels to the rest of the drawer box. Repeat for the remaining drawers.

Caution: Please ensure all cabinets are screwed into your timber stud wall. If attaching to concrete, brick, steel or other sub surfaces seek advice from your hardware specialist. WARNING: Do not allow children to climb on this furniture – it may topple over and badly injure a child.

Do not place toys or other child appealing items on top of this furniture. For advice or any other questions you may have, call customer service on: AU Customers: 1800 666 078 between 8:00am - 6:00pm E.S.T Monday to Friday NZ Customers: 0800 522 663 between 8:00am - 6:00pm E.S.T Monday to Friday

kitko.

KITCHEN SOLUTIONS

# 600mm 3 DRAWER CABINET

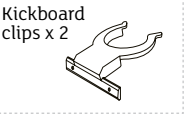
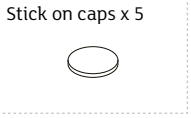
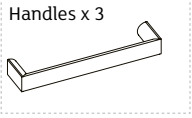
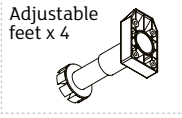
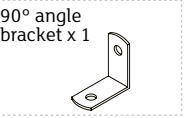
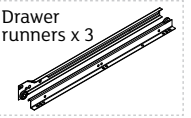

## STEP 10

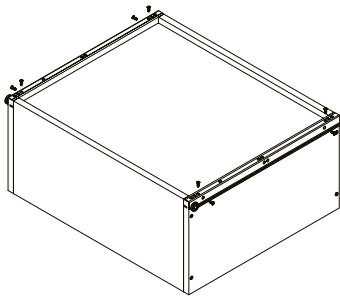

**Note:** The guide wheel end of the drawer runner should be flush with the end of the drawer box.

Lay drawer box face down and place drawer runners on the edge of the drawer. Secure in place using the 14mm screws.

## STEP 11

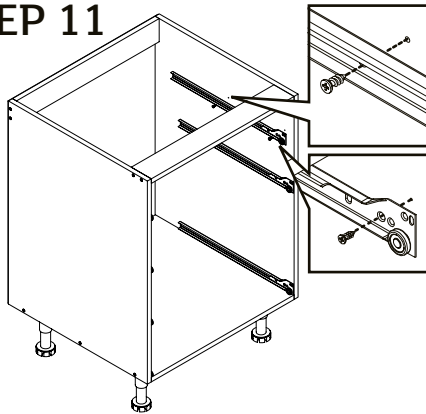

Place drawer runner on the side of the cabinet and align with the predrilled holes. Secure with the 14mm screws provided. Repeat for the remaining drawer runners.

## STEP 12

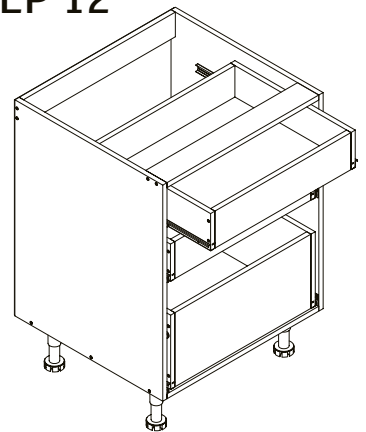

Slide drawer boxes into the cabinet along the runners.

## STEP 13

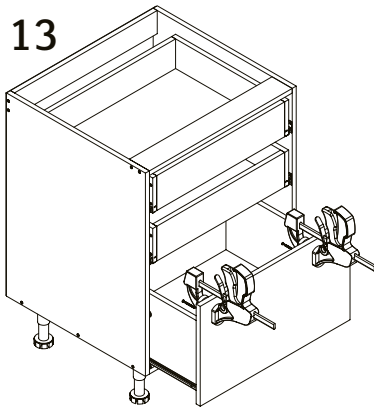

Clamp the drawer front onto the bottom drawer ensuring it is evenly spaced either side and level with the bottom panel of the cabinet. Predrill and attach using the 28mm screws provided.

## STEP 14

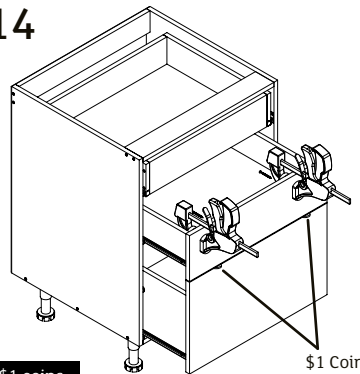

**Note:** Use 2 x \$1 coins as spacers between the drawer front panels.

Clamp, predrill and attach the remaining drawer front panels using the 28mm screws provided.

## STEP 15

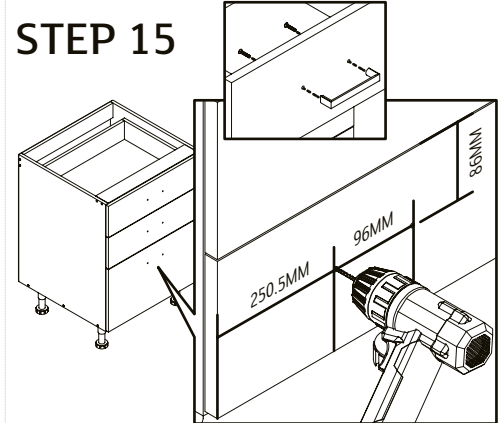

Place masking tape on both sides of the drawer front where holes will be drilled to avoid chipping. Pre-drill using 4.5mm drill bit. Attach handle using the screws provided.

## STEP 16

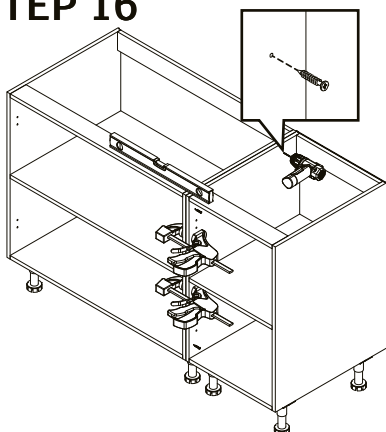

Check cabinets are level then clamp together. Pre-drill using 2mm drill bit and attach cabinets together.

## STEP 17

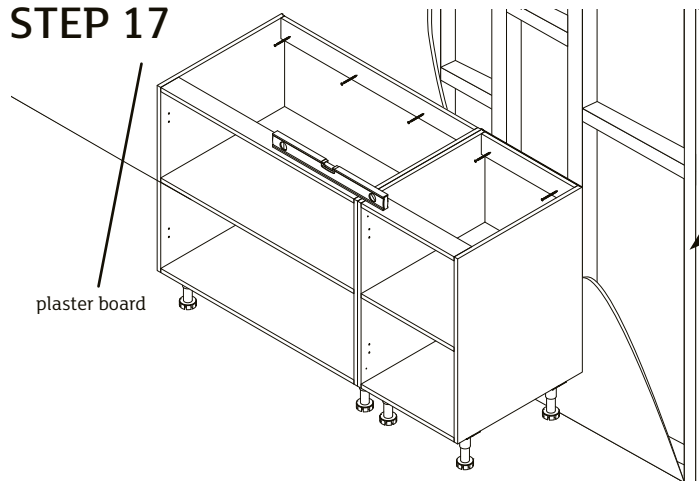

**Caution:** Please ensure all cabinets are screwed into your timber stud wall using a minimum of 60mm timber screws. If attaching to concrete, brick, steel or any other substrates seek advice from your hardware specialist.

Caution: Please ensure all cabinets are screwed into your timber stud wall. If attaching to concrete, brick, steel or other sub surfaces seek advice from your hardware specialist. **WARNING:** Do not allow children to climb on this furniture – it may topple over and badly injure a child.

Do not place toys or other child appealing items on top of this furniture. For advice or any other questions you may have, call customer service on:  
 AU Customers: 1800 666 078 between 8:00am - 6:00pm E.S.T Monday to Friday  
 NZ Customers: 0800 522 663 between 8:00am - 6:00pm E.S.T Monday to Friday